



Batch/Dual Counter

S662 Preset Batch/Dual Counter

- **Easily Programmed from the Front Panel**
- **Software Functions Include:**
 - Password* *Display Scaling*
 - Set Point Programming* *Decimal Point Selection*
- **Screw Terminal Connectors for Easy Installation**
- **Rugged, High-Impact Plastic Case Fits Standard 1/8 DIN Cutout**
- **3.24" (82mm) for Restricted Space Behind Panel**
- **NEMA4X/IP65-Rated Front Panel**
- **Remote Reset Capability**
- **Input Variety: Quadrature, Switch, TTL, CMOS, NAMUR, PNP, NPN**



The S662 is a multi-function counter that can be easily configured to operate either in a dual mode or in a totalizing /batch mode, each with separate scaling and reset functions. When functioning in the dual mode, full direction control is maintained for the totalizing and batch counts. In the totalizing batch mode, the secondary value (batch count) is incremented after the primary totalizing count has completed its cycle.

The S662 is compactly designed and features a standard 1/8 DIN case made of PBT-ABS alloy. Screw terminals are standard for easy installation and removal of the meter.

The counter is powered from 120 or 240VAC and has a non-volatile EEPROM to retain all programming and count information when the power source is removed or interrupted. An optional 12VDC (100mA) excitation output module can provide power for external sensors.

Optional field-replaceable single/dual relay modules enhance the counter from a passive display device to an integral control element for your application. This versatile counter has latching, boundary or timed (0.01 to 599.99 seconds) output modes.

Installation and Panel Cutout

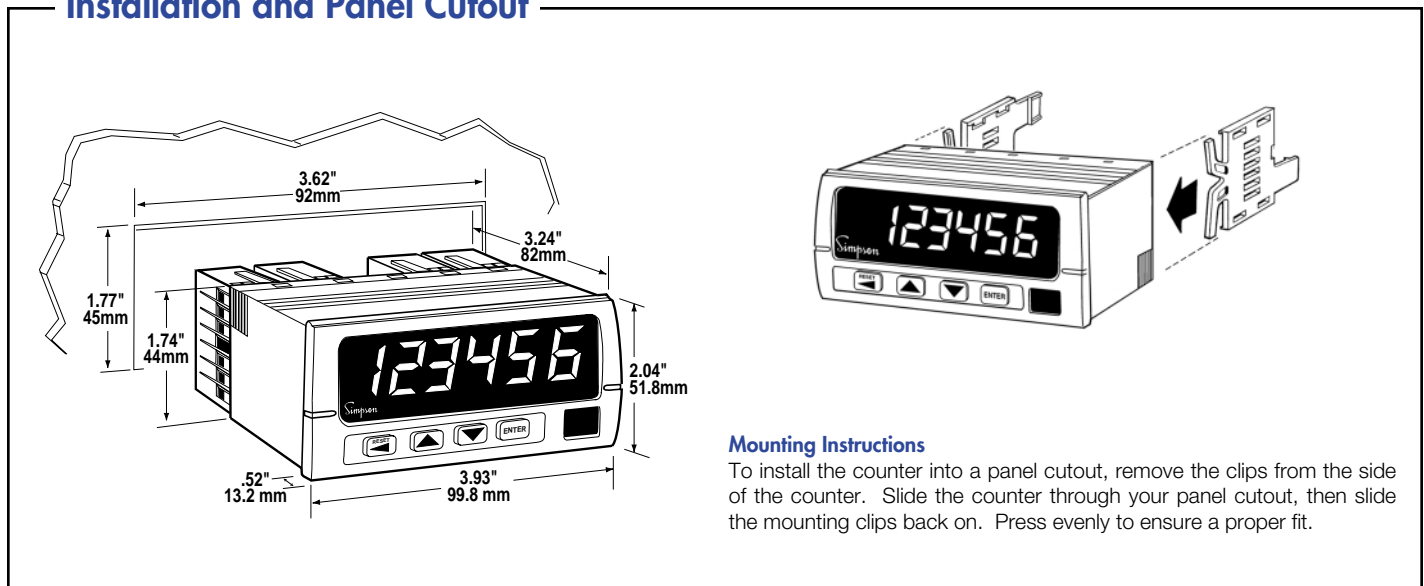

Specifications

DISPLAY

Type: 6-digit, 7-segment, red LED
Height: 0.56" (14.2mm)
Decimal Point: User-programmable
Count Direction: "+" indication implied, "-" indication displayed
Display Range: -99,999 to +999,999
Output Indicators: 1 and 2

POWER REQUIREMENTS

AC Voltages: 120, 240VAC, ±10%
Power Consumption: 3VA

INPUT RATINGS

Current Sinking: 10KΩ 5% Resistor Pull-up to (9.0 - 16VDC) ±10%
Current Sourcing: 5.1KΩ 5% Resistor Pull-down to common
Minimum Pulse Width: ~5μs

Low Pass Filter: <200Hz

Low Bias: VLT = 1.6V ±10% VUT = 3.6V ±10%

High Bias: VLT = 5.0V ±10% VUT = 7.0V ±10%

Count Rate: 20KHz (Pulse Max) 5KHz (Quadrature X4 Max)

Maximum Voltage Input

A, B, and User: 30VDC (Max)

INPUT

User Input: (Second channel reset) Count on the second channel is reset when the User Input is pulled low.

Standard Input: VLT ≤0.2VDC guaranteed low, VUT = 3.0VDC (max)

Quadrature Input: VLT ≤ 0.9VDC VUT =3.15VDC (max)

ENVIRONMENTAL

Operating Temp.: 0°C to +55 °C

Storage Temp.: -10 °C to +60 °C

Relative Humidity: 0-85% non-condensing

Ambient Temperature: 25°C

Temp. Coefficient (per °C): ±100PPM/ °C

Warmup Time: 15 minutes

MECHANICAL

Bezel: 3.93" x 2.04" x .52"
 (99.8mm x 51.8mm x 13.2mm)

Depth: 3.24" (82mm)

Panel Cutout: 3.62" x 1.77" (92mm x 45mm)

Case Material: PBT-ABS

Weight: 9oz (255.1g)

Wiring Diagram

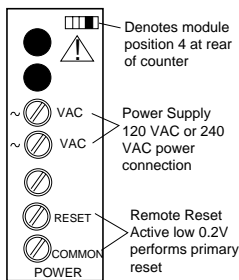

AC Power Module

Power Module: The AC power module allows the S662 to be operated from standard 50/60Hz line power. The power module will be configured as 120 or 240VAC per markings on the back panel. Ensure the input rating of the supply matches your line voltage. The power supply module has provisions for a hardwire Count Reset. This control can be a switch, relay contact, or solid state device. The reset circuit is independent of the power circuit.

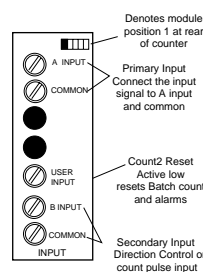

Standard Input Module

Note: The input boards are designed so that selecting sourcing or sinking is based on the type of sensor that is being used. If a PNP (sinking) sensor is being used, set the input board for sinking also (switches 3 and 6 = OFF). If channel B is not used, default settings for switch positions 1 through 3 should be selected.

Input Module: The DIP switch SW1 is used to set up the counter to conform to the electrical characteristics of the sensor or signal being detected. Switch positions 1-3 configure channel B, while switches 4-6 configure channel A. These switches select bias (threshold voltages), low pass filter (enable/disable), and sensor type (Sink or Source). Refer to the sensor's documentation for related information.

The input module also provides for a user input signal. On the S662, this input serves as a secondary channel (batch) hard-wire reset. This may be used to reset the batch count while preserving the primary count.

Programming

Menu Category	Parameter Name	Choices/Format	Description
	Pass	000 *	Password Entry and Verification
	Access <—	—> denied	Password Fail <i>Appears if incorrect password entered</i>
	ChPass	000	Password Change <i>Appears if correct password entered. 000 = password protection disabled. 001-099 = secures all parameters. 100-999 = enable SPs/ Res Pos access in display mode.</i>
Input Setup	A Chan	UP * Dn Quad r quad	Chan A Mode Select count mode of A channel.
	B Chan	Dir * UP Dn	Chan B Mode Select count mode for B channel. Note: If A channel set to Quad or R quad, this item is not accessible.
Count1 Setup	sCALE1	01.000 *	Count 1 Scale Set Display Value 1 scaling multiplier. Values: -9.9999 to 99.9999.

*Default Setting

Programming (Cont'd)

Menu Category	Parameter Name	Choices/Format	Description
Count1 Setup	dp	000000 * 000000. 00000.0 0000.00 000.000 00.0000 0.00000	Count 1 DP Display Value 1 Decimal Point location. Affects appearance of RstPos and any associated set point parameters.
count 2 Setup	Mmode	DuAL bAtch *	Batch Mode Display Value 2 (Count 2) mode. Defines the counting mode for batch count.
	prescl	1.0 * 0.1 0.01 0.001	Count 2 PreScale Set pre-scaling multiplier for Display Value 2.
	scale2	01.0000 *	Count 2 Scale Set Display Value 2 (Batch) scaling multiplier. Values: -9.9999 to 99.9999.
	dp2	000000 * 00000.0 0000.00 000.000 00.0000 0.00000	Count 2 DP Display Value 2 Decimal Point location. Affects appearance of RstP 2 value and any associated set point parameters.
OPUT 1 SETUP	MMode1	Disabl timmed latch * bound	Output 1 Mode Set the mode of operation for Output 1. Can be disabled, timmed, latched or boundary mode.
	src1	count1 * count2	Output 1 Source Select which Display Value to be used for output 1 comparisons/matchpoints. See also SP1 and SP2 .
	batrst	no * yes	Output 1 Batch Reset When output activates, perform Count 2 Reset as well.
	Timmed <— Latched <— SP1=Lo <—	—> At SP1 —> At SP1 * —> SP2=hi	Output 1 Bindings Reminder message indicates which and how the set points are used for comparison. Which message is displayed is determined by the Output 1 Mode selected.
	Delay1	010.00 *	Delay 1 Output 1 delay time. <i>Appears only if Output 1 mode set to timed.</i>
	Until1	Reset * SP1 SP2 SP3 SP4 RstP1	Until 1 Output 1 latched until parameter. <i>Appears only if Mmode1 = latch and SRC1 = Count.</i>
oput 2 SETUP	MMode2	Disabl timmed Latch * bound	Output 2 Mode Set the mode of operation for Output 2. Can be disabled, timed, latched or boundary mode.
	src 2	count1 * count2	Output 2 Source Select which Display Value to be used for output 2 comparisons/matchpoints. See also SP3 and SP4 .
	batrst	no * yes	Output 2 Batch Reset When output activities, perform Count 2 Reset as well.
	Timmed <— Latched <— SP3=Lo <—	—> At SP3 —> At SP3 * —> SP4=Hi	Output 2 Bindings Reminder message indicates which and how the set points are used for comparison. Which message is displayed is determined by the Output 2 Mode selected.
	Delay2	010.00 *	Delay 2 Output 2 delay time. <i>Appears only if Output 2 mode set to timed.</i>

*Default Setting

Programming (Cont'd)

Menu Category	Parameter Name	Choices/Format	Description
oout 2 SETUP	until2	reset * sp1 sp2 sp3 sp4 rstp1	Until 2 Output 2 latched until parameter. <i>Appears only if mmode2 = latch and src2 = count1.</i>
oout 2 SETUP	sp1	000010 *	SP1 Set point #1 Low. Values: -99999 to 999999. Decimal point will appear according to the current Output 1 Source setting.
	sp2	000020 *	SP2 Set point #1 High. Values: -99999 to 999999. Decimal point will appear according to the current Output 1 Source setting.
	sp3	000030 *	SP3 Set point #2 Low. Values: -99999 to 999999. Decimal point will appear according to the current Output 2 Source setting.
	sp4	000040 *	SP4 Set point #2 High. Values: -99999 to 999999. Decimal point will appear according to the current Output 2 Source setting.
	rstp1	000000 *	Count 1 Preset Value Count 1 value is set to this when an Auto or Manual Reset event occurs. Values: -99999 to 999999. Decimal point will appear according to the user programmed Batch DP2 position.
	rstp 2	000000 *	Count 2 Preset Value Batch value is set to this value when a Batch Reset event occurs. Values: -99999 to 999999. Decimal point will appear according to the user programmed Batch DP2 position.
Resets SETUP	areset	disabl * at sp1 at sp2 at sp3 at sp4 aftop1 aftop2	Auto Reset Mode Selects when an auto reset function is to occur. Disabled, at a set point or after output times out. See also the rstp1 parameter in the setpnt setup category.
	rstbtn	yes * no	Reset Button Enable or disable front panel reset button.
	PonRst	No * Yes	Power On Select whether count reset event will occur at power-up.
End			Exit Programming Menu

*Default Setting

Excitation Output

The Excitation Module can supply 12VDC at up to 100mA for external sensors or encoders. This excitation is isolated from the counter internal logic supply.

When using sensors or encoders that do not have a signal return that is in common with the supply voltage, a common attachment which ties the excitation supply to the logic input common may be required.

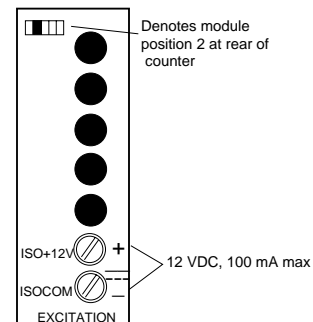

Single and Dual Relay Modules

The Single and Dual Relay modules can activate circuit loads of up to 5 amps at 250VAC. A Form C configuration allows use of normally-open (NO) and normally-closed (NC) circuit action.

Only the output 1 channel is implemented in the single relay module.

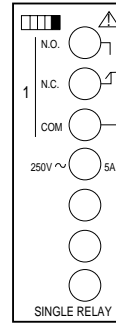

Single Relay Module

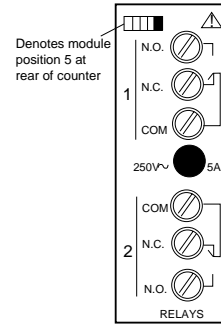

Dual Relay Module

Application Example

A Simpson Counter is to be used to indicate when the 100th play on a new game machine has been completed. The casino owner will award a promotional gift to the lucky customer. This special promotion is independent of the machine's normal payout.

An attention-getting rotating beacon will announce the winner. Use the S662 batch counter to perform 100th game play detection and to give the total number of 100th game winners.

Beacon Lamp: Power requirement is 120VAC, 0.5 amp maximum.

Procedure: The 'winner' is to be announced after the 100th game is completed. When this occurs, the beacon lamp must activate and the game counter reset to 0. The indicator is to remain on for 10 seconds.

Machine Specifications

Game Machine: The machine has an 'auxiliary' contact available which is traditionally used for a cycle counter option. The contact is closed whenever a game is in progress.

Product Ordering Information

In the above application example, a Simpson S662 Preset Batch/Dual Counter with a 120VAC power supply, Quadrature Input, Single Relay Output, and no excitation is used (catalog no. S662-1-2-1-0-0).

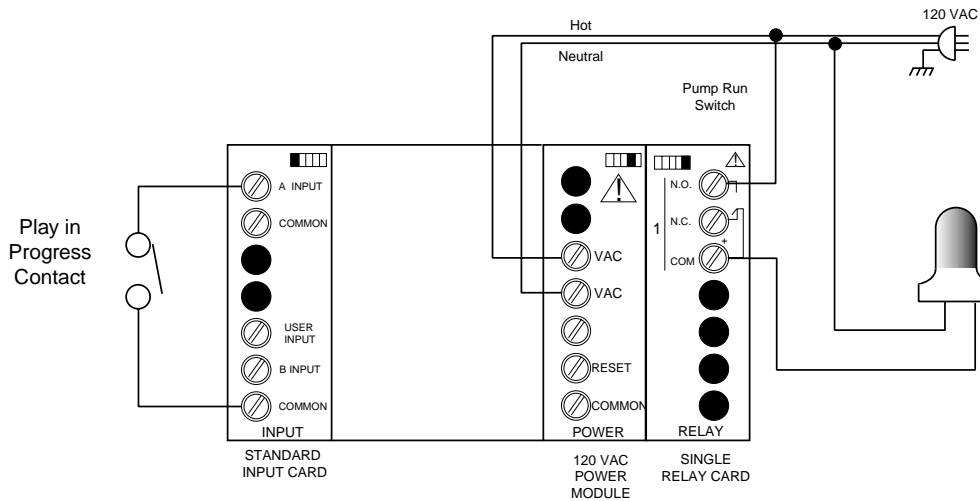

Ordering Information

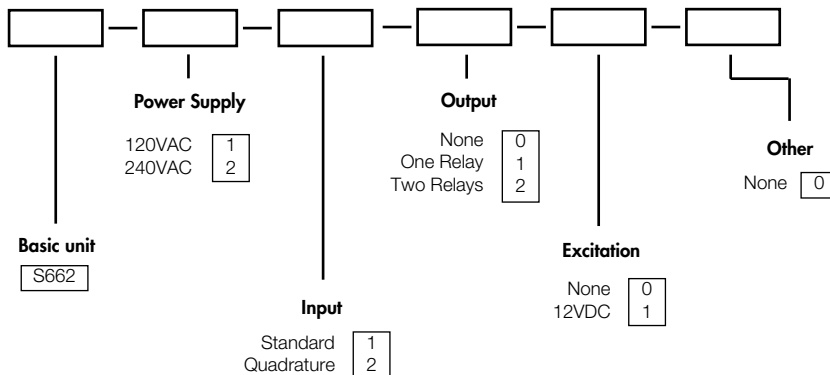

Safety Symbols



The WARNING sign denotes a hazard. It calls attention to a procedure, practice, or the like, which if not correctly performed or adhered to, could result in personal injury.



The CAUTION sign denotes a hazard. It calls attention to an operating procedure, practice, or the like, which if not correctly adhered to could result in damage to or destruction of part or all of the instrument.

